

SECURITRON PRIME TIME MODEL DT-7 INSTALLATION AND OPERATING INSTRUCTIONS

1. DESCRIPTION

Securitron's Prime Time is a daily or weekly digital timer which operates on 12 to 24 volts AC or DC and energizes and deenergizes a 10 Amp double pole, double throw relay according to instructions set over a week. Toggle, or 2 types of pulsed relay operation may be selected.

2. POWER UP AND TIME SETTING

Identify terminals 1 and 2 marked "12-24 AC/DC". Apply a voltage source in this range to these 2 terminals. **If a substantially greater voltage is applied the unit will be damaged.** Current drawn is 160 mA when the unit's relay is energized and 10 mA when the relay is deenergized regardless of input voltage. Note that if DC voltage is used for power, polarity is unimportant.

When power has been applied, the liquid crystal display on the rectangular plastic timer module will come on showing the word "off" and "0000". The next step is to input the current time of day into the timer module. To set the time of day, push and hold down the button farthest on the left which shows the clock symbol. While holding this button down, set the hours by repeatedly pushing the "H+" button. Note that if this button is held down, the hours will automatically increment. Note also that the unit does not use AM and PM designation for the hours, but rather employs military time based on a **24 hour system**. For example, 22:00 hours is the same as 10:00 PM.

In similar fashion, set the minutes by depressing the "M+" button while holding down the clock symbol button. Finally, set the day of the week by pressing the day button while holding down the clock symbol button. Once the time of day and the day of the week have been entered you can release the clock symbol button.

FIG. 1: PRIME TIME OVERVIEW

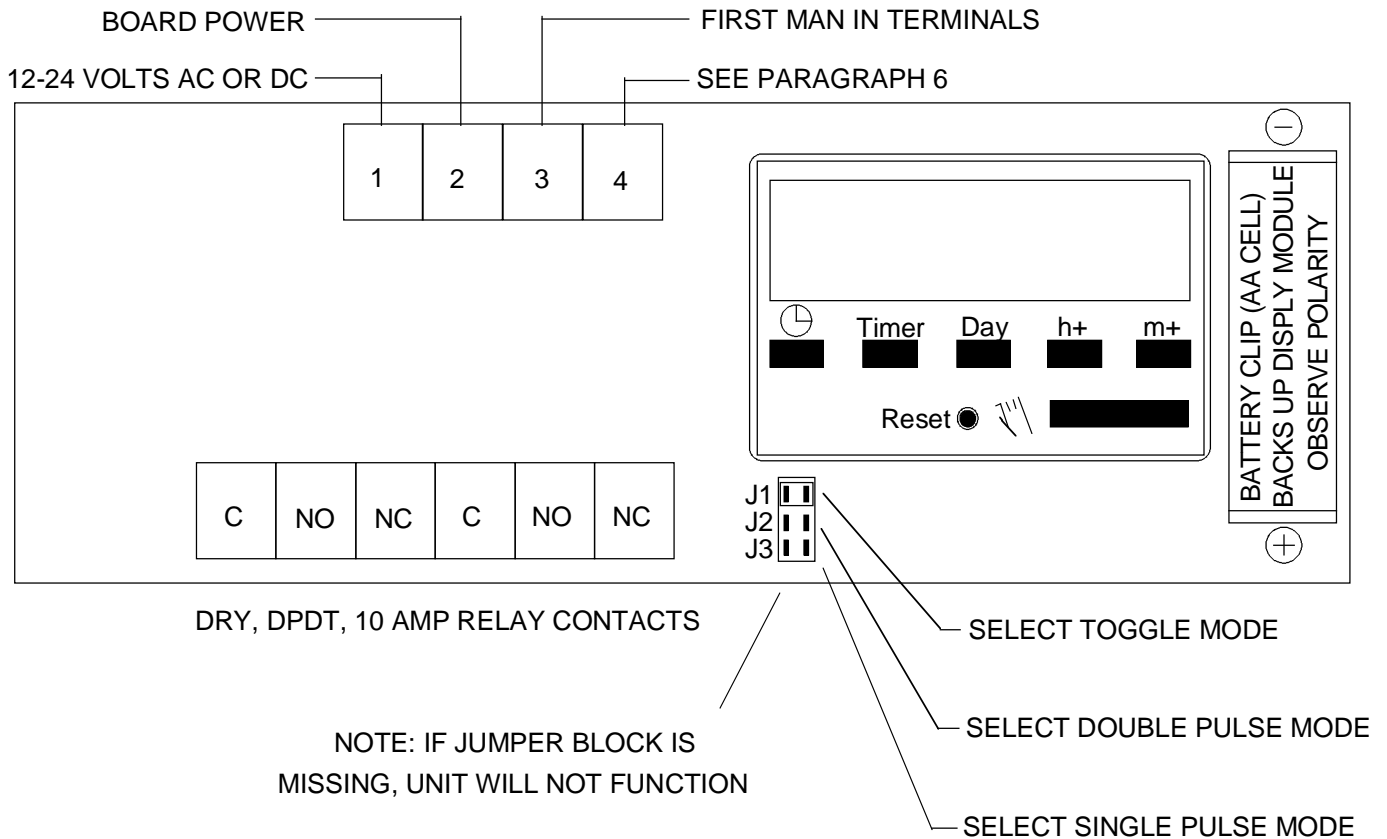

3. TOGGLE MODE

The toggle mode is selected when the jumper block is set to the "J1" (factory set) position. **Note that if the jumper block is missing, the relay will stay energized all the time and the unit will not perform any function.** In the toggle mode, the Prime Time is programmed to turn electrical devices on or off at selectable times over a week period. The Prime Time accomplishes this by energizing or deenergizing a 10 Amp DPDT relay. Note the terminal strip with 6 terminals marked "C", "NC", and "NO" for each pole. Devices to be controlled by the Prime Time should be connected to these terminals which are isolated (dry) relay contacts.

Note on the display that the term "off" appears to the left of the hours display. This indicates that the relay is off or deenergized. Note finally the long push button on the timer module with a hand symbol printed next to it that is situated below the "H+" and "M+" push buttons. Pressing this button while the unit is in operating mode (time is showing) will allow you to manually energize and de-energize the relay. As you do this the display will change from "off" to "on" and back again. This is useful for testing and for temporarily changing the state of the relay.

4. PULSE MODES

Moving the jumper block to position "J2" selects the **double pulse mode**. In this mode, when the display module executes an "on" or "off" instruction, the relay pulses (energizes) for 1 second and then returns to a deenergized state. This is useful for controlling devices that require a momentary pulse to turn on and off such as many alarm panels. In the pulse modes, the test button function and relay connections are the same as in the toggle mode described in the previous section. As you use the test button, the display will change from "on" to "off" (and back), and you will be able to see and hear the relay contacts switching for one second. Remember, the pulse modes affect what the relay does, not how the display changes.

Moving the jumper block to position "J3" selects the **single pulse mode**. In this mode, the relay will pulse when an "on" instruction executes (display changes from "off" to "on") but not when an "off" instruction executes. This allows sending a pulse signal once a week- to test a dialer for example. When working with any of the modes, liberal use of the test button will permit easier understanding.

5. PROGRAMMING

To program the on/off times, depress the push button marked "timer" once. This enters the programming mode. The display will now change and indicate "timer 1 on". Pressing the timer button again will display "timer 1 off". If you continue to depress the timer button, you will step through 6 "on" timers and 6 "off" timers. These represent a total of 12 program instructions. At start up, all of the instructions are inactive, which is indicated by the fact that they do not show any time or day but merely show horizontal lines. To make any of the 12 instructions active, you must input an hour, minute, and day by pressing the "H+", "M+" and day buttons just as you did when you first set the time. **If, however, a day of the week is not input, the instruction will be executed daily.** This is how to use the Prime Time to execute the same program each day.

When an "on" instruction executes in the toggle mode, it will energize the relay on the time and day selected. In the double or single pulse mode the relay will energize for 1 second. An "off" instruction will deenergize the relay in the toggle mode, pulse it in the double pulse mode and have no effect in the single pulse mode. If the display is already "on" and an "on" instruction executes, nothing will happen. Programmed instructions only function when they change the state of the display. The relay then responds according to the mode selected. All 12 instructions may, if desired, be used during the same day or be spread out throughout the week which is more common. The fact that the instruction sets are labeled 1 through 6 has no significance. The instructions will be executed whenever the time and date of the instruction occurs.

It is important to understand how the unit works in terms of executing its program. Think of the programmed "on" and "off" instructions as markers on a 7 day schedule. Then think of the digital clock as moving through this 7 day period, minute by minute. When the clock encounters an instruction, it will execute the instruction by turning on or off (if it is not already in the state called for in the instruction). Sometimes, we get the following type of question from an installer on initial set-up: "I put in an 'on' instruction for 8:00 am today. It's now 10:00 am and the relay is showing 'off'. Why doesn't it turn on?" The answer is that the DT-7 does not check what time it is and then look to see if it is "supposed" to be on or off. It just advances its clock, minute by

minute, and when it encounters an instruction, it executes the instruction. On initial set-up, use the test button to put the unit in the desired initial state.

If an on and off instruction both occur at exactly the same time and day, the **off instruction will be executed and the on instruction will be ignored**. An instruction is **erased** by incrementing the hours, minutes, and day buttons to restore the horizontal (null) lines. Note that momentarily pressing the **reset** detent will eliminate all program data from the unit as well as eliminating the time setting. The reset detent has the same effect as removing all power (including the battery) from the unit.

FIG. 2: TIME SETTING AND PROGRAMMING

DISPLAY MODULE: OPERATING MODE AND TIME SETTING

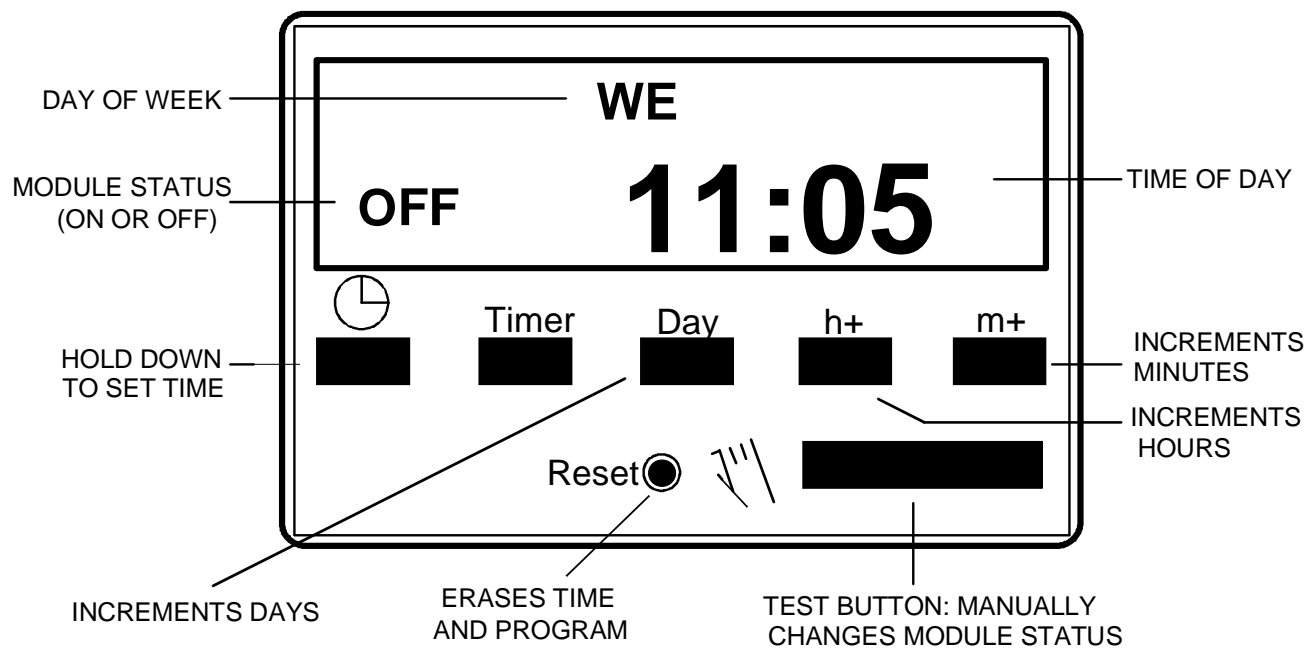

DISPLAY MODULE: PROGRAMMING MODE

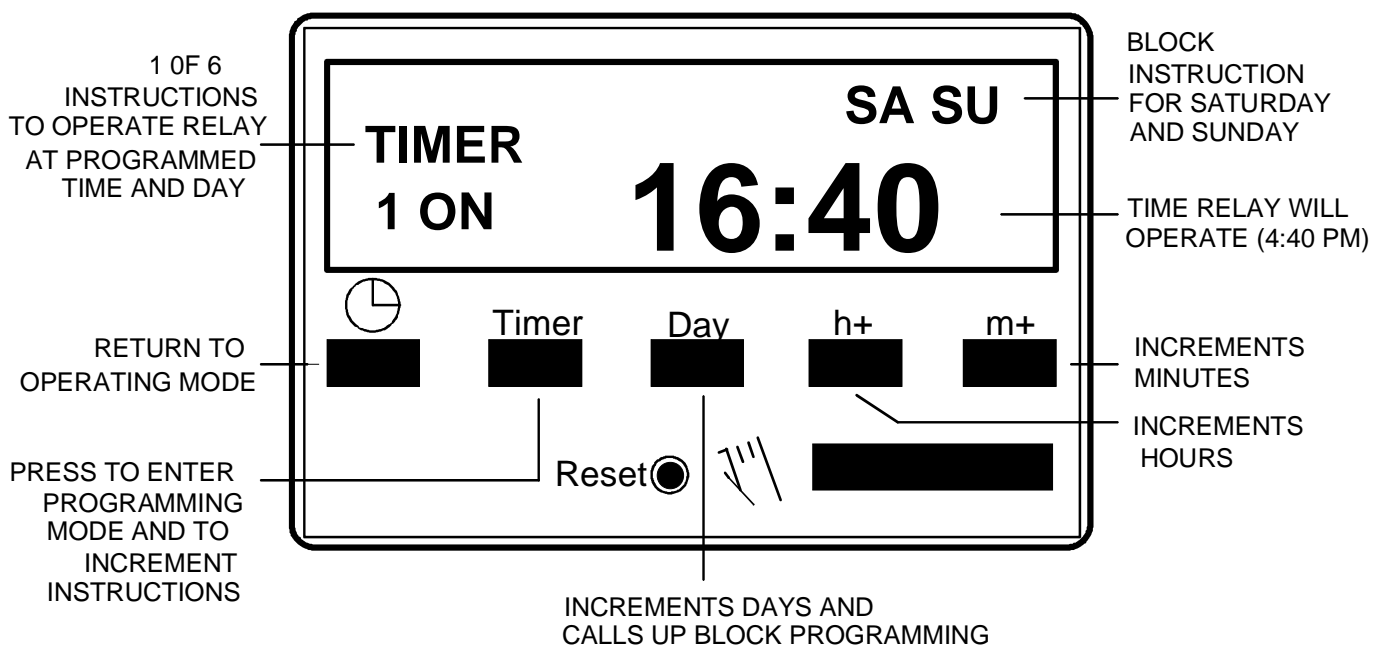

5.1 BLOCK PROGRAMMING

A common requirement is that programmed on/off times will be the same each day during the week and differ on the weekend. To achieve this result, it is not necessary to program on/off times separately for each day. Indeed, since there are only a total of 12 instructions, only 6 days can be handled with different on/off times. Block programming is used to handle this common need, which makes the Prime Time quick and easy to program.

When programming a timer instruction, as you press the day button, you will step through individual days from Monday through Sunday. Pressing the day button 1 more time will show a Monday through Friday block. If you leave the instruction in this position it will be executed on each displayed day. Depressing the day button again will show a Saturday/Sunday block. Depressing it still another time will show a Monday through Saturday block.

After you have set an instruction, depressing the timer button again will open a new instruction and enter the previous one. When all instructions have been entered, press the clock symbol which will again display the time and day of the week. The instructions will now execute until changed. Instructions can be changed at any time by bringing them up on display and altering the time and day or erasing the instruction by incrementing it to the horizontal line state.

5.2 TYPICAL PROGRAMMING EXAMPLE

A very common application for the Prime Time is activating and de-activating a security system at the same time each day during the week and then leaving the security system active over the weekend. With block programming this is extremely simple. Enter into "timer 1 on" the time "08:00" assuming for this example that's the time each day you want the system de-activated. Then enter the Monday through Friday block of days also on "timer 1 on". Then switch to "timer 1 off" and enter "17:00" (5:00 pm) again selecting the Monday through Friday block. At 5:00 p.m. each day this should turn the security system on. No further instructions need be entered because at 5:00 pm on Friday you want the system to remain on until Monday morning when the "on" instruction will execute at 8:00 am turning the security system off. If the security system consists of electric locks, you would use the toggle mode such that when the relay is energized, the locks are off and visa versa. If the system is an alarm panel using pulsed input, you would use the double pulse mode. The programming, however, is the same.

We advise that when the display indicates "on" the system should be off. This requires use of the appropriate relay contacts depending on the type of load and the mode. The reasons for this have to do with ease of holiday programming and use of the "First Man In" terminals described in section 6.

5.3 HOLIDAY PROGRAMMING

Having established the weekly block program described above, lets say that a holiday occurs on a Wednesday during which the security system is to be left on. Normally as the weekly block program is executed, an 8:00 am "on" instruction will turn the system off. You could of course void the entire weekly program and put in a daily instruction just to deal with the holiday, but this is needlessly complicated and requires re-establishing the original program after the holiday. What's easier is to put in an **override command**. Leaving the weekly block program intact you call up "timer 2 off" and put in a command for Wednesday at 8:00 am. This will duplicate the weekly block program which instructs the Prime Time to turn on Wednesday at 8:00 am and **the off instruction has priority**. Therefore, the on instruction will be ignored and all day Wednesday the security system will stay on. After the holiday, you have only to void out the single instruction on "timer 2 off".

A more powerful way to deal with holidays that works for many applications is described in the next section.

6. USE OF FIRST MAN IN TERMINALS

Terminals 3 and 4 are labeled "First Man In". If they are unconnected they have no effect on operation of the unit as described so far. Connecting them to an external switch or relay can make operation of the Prime Time more powerful.

The best way to understand this feature is to use an application as an example. Returning to our example cited in section 5.3, a security system deactivates at 08:00 each morning and resecures at 17:00 hrs. Suppose everyone's late to work one day because (for instance) of bad weather. The facility will be completely unprotected. A better way to operate would be for the

first man to arrive each morning to deactivate the system for the day after which it automatically reactivates at the end of the day. This is accomplished by connecting dry N.C. contacts from an external device, to the First Man In terminals (3 and 4). This puts the Prime Time into **First Man In mode**. When the unit executes an "on" instruction, the output relay does not operate **until the contacts on 3 and 4 open once**. When they open, the relay follows the "on" program which means energizing in the toggle mode or pulsing 1 second in the double pulse mode. The First Man In terminals do not have any effect in the single pulse mode. Subsequent state changes of the contacts on 3 and 4 have no further effect on the relay during the time the display module is "on". When an "off" instruction executes, the state of the First Man In terminals again have no effect. **They act only to delay the operation of an "on" instruction.**

Returning to our example, let's say the security system consists of an electric lock with digital keypad for entry. The Prime Time is used in the toggle mode. At night, the display module reads "off" and power is sent to the electric lock to secure it through the Prime Time's output relay's N.C. contacts. One pole of the digital keypad's output relay will break power to the electric lock allowing nighttime entry and the other pole's N.C. contacts connect to the First Man In terminals of the Prime Time. If someone comes to work at 07:45 am, the Prime Time is still "off" so they use the digital keypad for entry. When 08:00 comes, the display module switches to "on" but the operation of the Prime Time output relay is delayed **because of the closure across the First Man In terminals from the keypad**. When another man arrives at 08:10, he also uses the digital keypad and with this first operation (after 8:00 am), the Prime Time's relay energizes and releases the lock so that all subsequent people can freely use the door during the day. At 17:00 the unit goes into nighttime mode (off) and deenergizes the relay. The same results can be obtained in the double pulse mode. The pulse that would occur when an "on" instruction first executes is delayed until the first man in terminals open.

In addition to avoiding leaving a facility unprotected in the event that employees are late to arrive, **the First Man In feature can eliminate the need for holiday programming**. Returning to our example, if we define a holiday as a day no one comes to work, no one will use the digital keypad so the electric lock will remain secure all day. When the display module switches to "off" at the end of the holiday, the lock will simply continue secure and then resume its normal non-holiday operation the following day. If a particular manager comes to work on the holiday with this operational concept, he can either leave the lock unsecured all day while he is there, or change the display module from "on" to "off" by pressing the test button. This action will resecure the lock. When the 17:00 "off" instruction seeks to execute, the unit will already be off, so the lock will remain secure during the night as it should.

7. WIRING

Figure 3 shows three "typical" examples of wiring the Prime Time in actual applications. The first drawing shows the most common use which is simply to switch a device or system on and off in toggle mode. The second drawing shows use of the pulse mode in the most common security industry application: that of arming and disarming an alarm panel. Note that there is a risk in using this set-up in that if the alarm panel is not in the "ready to arm" condition, the pulse from the Prime Time will not arm the panel. When the next command comes up and the panel should be disarmed, the panel will interpret the next pulse as another attempt to arm. Therefore, the Prime Time should only be used to arm and disarm alarm panels in applications where either they are always "ready to arm" or there is some monitoring which will quickly detect the fact that there has been a failure to arm.

The third drawing shows the particular application example discussed in section 6 on use of the First Man In feature with an electric lock and DPDT digital entry keypad. It is intended to display the general principle as, obviously, other applications are possible. Finally note that the Prime Time relay is a socket mount. If the relay is damaged from a load short circuit (for instance) it can be replaced by simply plugging in a new relay. Replacement relays are available from Securitron or locally from an electric product wholesaler. The relay part number is LY2-DC6 as manufactured by Omron Electronics. If an Omron part is not available, the equivalent cross from other manufacturers will work (be sure to specify a 6 volt DC coil). This relay physical type is very common.

FIG. 3: PRIME TIME WIRING EXAMPLES

TYPICAL WIRING: TOGGLE MODE

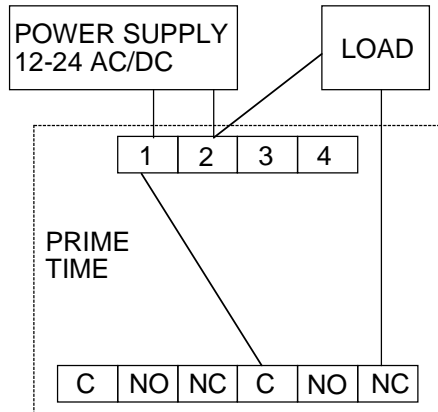

NOTE: JUMPER BLOCK SET TQJ1

NOTE: LOAD USES SAME POWER AS DT-7. IF LOAD REQUIRES DIFFERENT POWER, SUCH AS 115 VAC, RELAY CONTACTS SHOULD BE ISOLATED FROM DT-7 POWER.

TYPICAL WIRING: DOUBLE PULSE MODE
USE WITH ALARM PANEL SHOWN

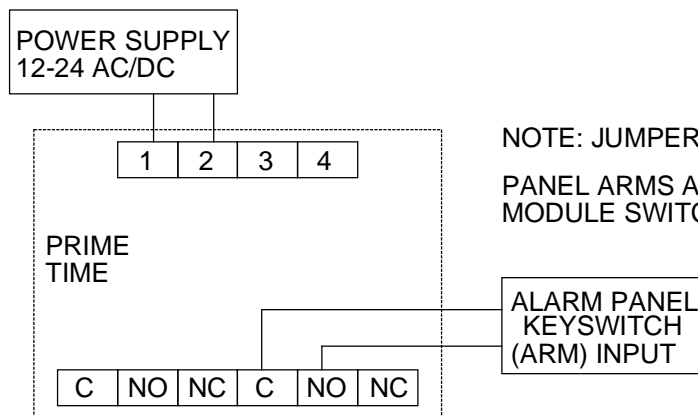

NOTE: JUMPER BLOCK SET TO J2

PANEL ARMS AND DISARMS AS DISPLAY MODULE SWITCHES ON AND OFF

TYPICAL WIRING: TOGGLE MODE WITH FIRST MAN IN ACTIVE
USE WITH ELECTRIC LOCK AND DIGITAL KEYPAD FOR TIME CONTROLLED ENTRY SHOWN

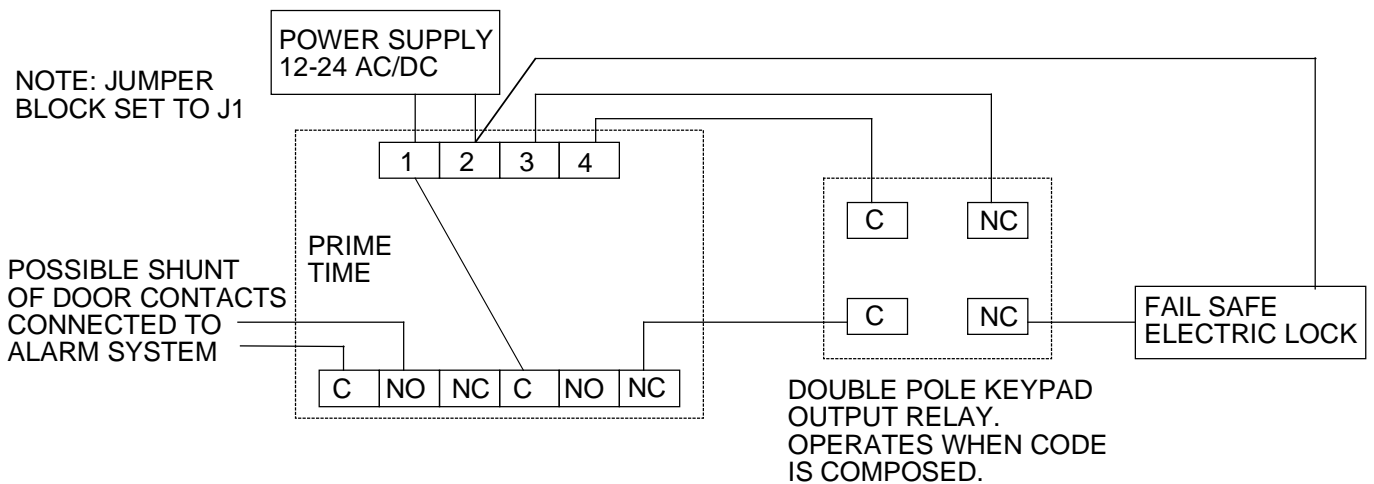

NOTE: JUMPER BLOCK SET TO J1

POSSIBLE SHUNT OF DOOR CONTACTS CONNECTED TO ALARM SYSTEM

DOUBLE POLE KEYPAD OUTPUT RELAY. OPERATES WHEN CODE IS COMPOSED.

NOTE: SEE PARAGRAPH 6 IN INSTRUCTIONS FOR FULL EXPLANATION OF FIRST MAN IN FUNCTION

8. DAYLIGHT SAVINGS TIME

When the time changes twice a year to and from Daylight Savings Time, the time in the unit must be adjusted as with any clock. See section 2. for time setting.

9. POWER FAILURE CONSIDERATIONS

If power is removed from the Prime Time, it will lose both the time and its programming and will have to be set up again from the beginning. In a DC application this can be forestalled by using a DC power supply with its own battery backup to operate the Prime Time. This will not only allow the Prime Time to operate in the event of a power failure, but will operate the DC loads as well.

If the Prime Time is to be operated on non-battery backed up external power, an AA cell may be added to the board in the space provided. **Be sure to observe polarity. The AA cell backs up the display module only.** In the event of an external power failure, the Prime Time's relay will not operate but the display module will retain the time and date as well as its programming. The average commercially available AA cell should last at least 5 years in this application.

MAGNACARE® LIMITED LIFETIME WARRANTY

SECURITRON MAGNALOCK CORPORATION warrants that it will replace at customer's request, at any time for any reason, products manufactured and branded by SECURITRON.

SECURITRON will use its best efforts to ship a replacement product by next day air freight at no cost to the customer within 24 hours of SECURITRON's receipt of the product from customer. If the customer has an account with SECURITRON or a valid credit card, the customer may order an advance replacement product, whereby SECURITRON will charge the customer's account for the price of the product plus next day air freight, and will credit back to the customer the full amount of the charge, including outbound freight, upon SECURITRON's receipt of the original product from the customer.

SECURITRON's sole and exclusive liability, and customer's sole remedy, is limited to the replacement of the SECURITRON product when delivered to SECURITRON's facility (freight and insurance charges prepaid by customer). The replacement, at SECURITRON's sole option, may be the identical item or a newer unit which serves as a functional replacement. In the event that the product type has become obsolete in SECURITRON's product line, this MAGNACARE warranty will not apply. This MAGNACARE warranty also does not apply to custom, built to order, or non-catalog items, items made by others (such as batteries), returns for payment, distributor stock reductions, returns seeking replacement with anything other than the identical product, or products installed outside of the United States or Canada. This MAGNACARE warranty also does not apply to removal or installation costs.

SECURITRON will not be liable to the purchaser, the customer or anyone else for incidental or consequential damages arising from any defect in, or malfunction of, its products. SECURITRON does not assume any responsibility for damage or injury to person or property due to improper care, storage, handling, abuse, misuse, or an act of God.

EXCEPT AS STATED ABOVE, SECURITRON MAKES NO WARRANTIES, EITHER EXPRESS OR IMPLIED, AS TO ANY MATTER WHATSOEVER, INCLUDING WITHOUT LIMITATION THE CONDITION OF ITS PRODUCTS, THEIR MERCHANTABILITY OR FITNESS FOR ANY PARTICULAR PURPOSE.